

Universal Desktop Battery Charger with Tester



Features:

- Charges 1 to 4 AAA, AA, C, D and 1 to 2 9V Ni-Cd / Ni-MH batteries simultaneously
- Charge times from 2 to 10 hours dependent on capacity
- Built-in battery tester indicates battery strength
- Discharge function
- UK plug

Electrical Data:

Input	Input Voltage / Frequency	230V / 50Hz
	Input Power	4.8W
Output	Rated Charging Voltage	1.2V (AAA, AA, C, D) 9V (block battery)
	Rated Charging Current	120mA (AAA, AA, C, D) 13mA (9V block battery)
	Rated Output Power	0.8VA
Resistance	Insulation Resistance	100M Ω (measured with 500V DC Voltage)
Protection	Thermal Protection	Thermal fuse cut off temperature:115°C
	Withstand Voltage (Hi-Pot)	3750V AC 50Hz for 1minute or 4000V AC 2 seconds

Mechanical Data:

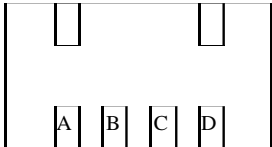
Supply Connection Type	VDE standard cable, Cross sectional area: 2 x 0.75mm ² , Plug: European type: in compliance with EN50075			
Primary Turns and Wire Gauge	4650T / ϕ 0.07mm			
Diagram of transformer terminals: primary  secondary	Secondary Turns and Wire Gauge			
	Leading terminal	Wire No.	Gauge (mm)	Turn (T)
	A-B	SWG33	0.25	134
	A-C	SWG33	0.25	134
A-D	SWG43	0.09	354	

Universal Desktop Battery Charger with Tester



Mechanical Data:

Core Size	35mm x 15mm
Insulating class	Class E
Unit Weight	480g
Dimensions (mm)	203 (L) x 110 (W) x 59 (H)

Part Number Table

Description	Part Number
CHARGER, UNIVERSAL NICD/NI-MH, UK PLUG	MW6398GS(UK)

Disclaimer This data sheet and its contents (the "Information") belong to the Premier Farnell Group (the "Group") or are licensed to it. No licence is granted for the use of it other than for information purposes in connection with the products to which it relates. No licence of any intellectual property rights is granted. The Information is subject to change without notice and replaces all data sheets previously supplied. The Information supplied is believed to be accurate but the Group assumes no responsibility for its accuracy or completeness, any error in or omission from it or for any use made of it. Users of this data sheet should check for themselves the Information and the suitability of the products for their purpose and not make any assumptions based on information included or omitted. Liability for loss or damage resulting from any reliance on the Information or use of it (including liability resulting from negligence or where the Group was aware of the possibility of such loss or damage arising) is excluded. This will not operate to limit or restrict the Group's liability for death or personal injury resulting from its negligence. SPC Multicomp is the registered trademark of the Group. © Premier Farnell plc 2010.

<http://www.farnell.com>
<http://www.newark.com>
<http://www.cpc.co.uk>

